

ULTIMA Anti-sway Wire System

More than 1 million units shipped in Japan for use as wire slide stops for lighting, air conditioning, and other equipment.

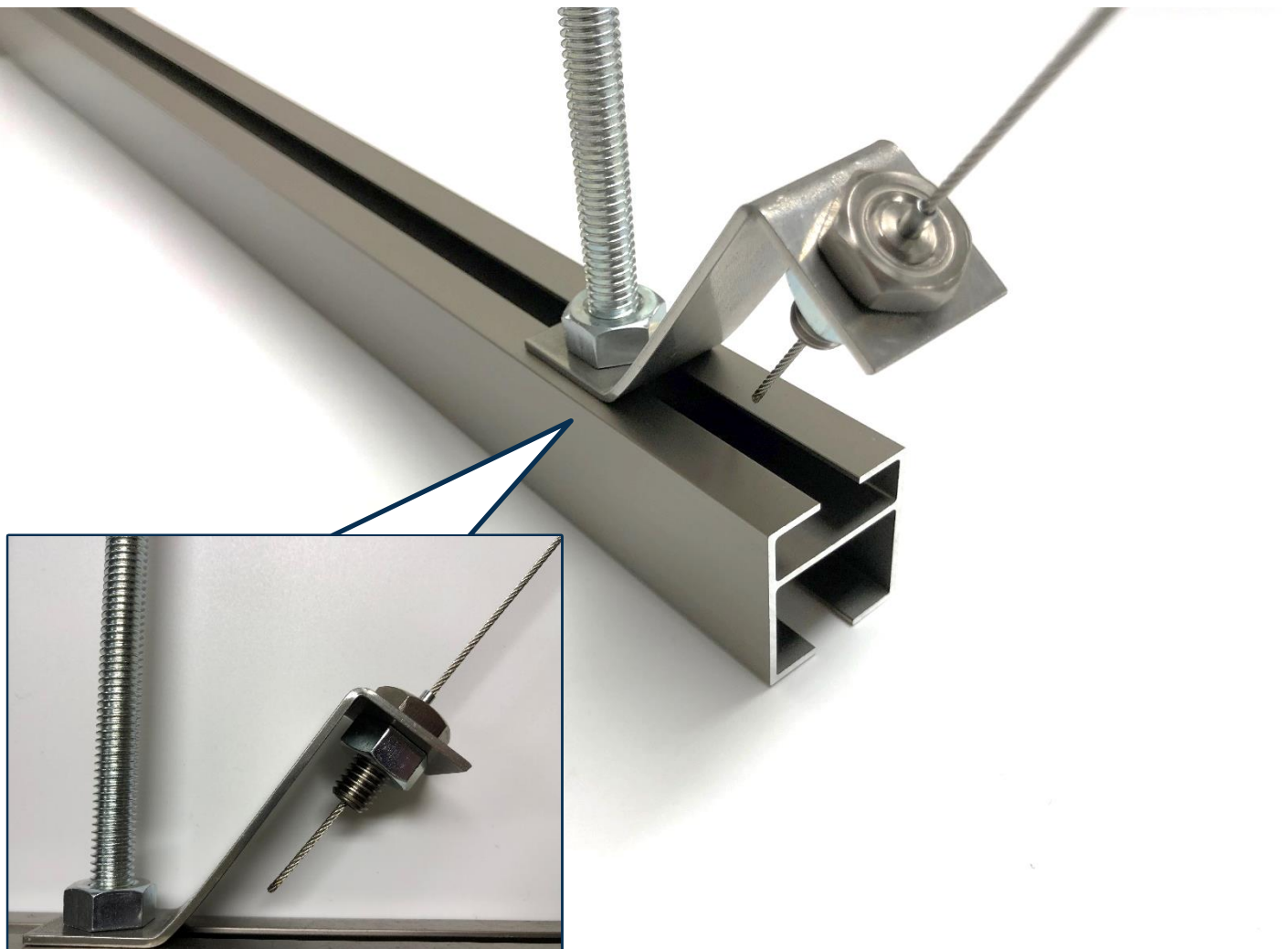

ULTIMA

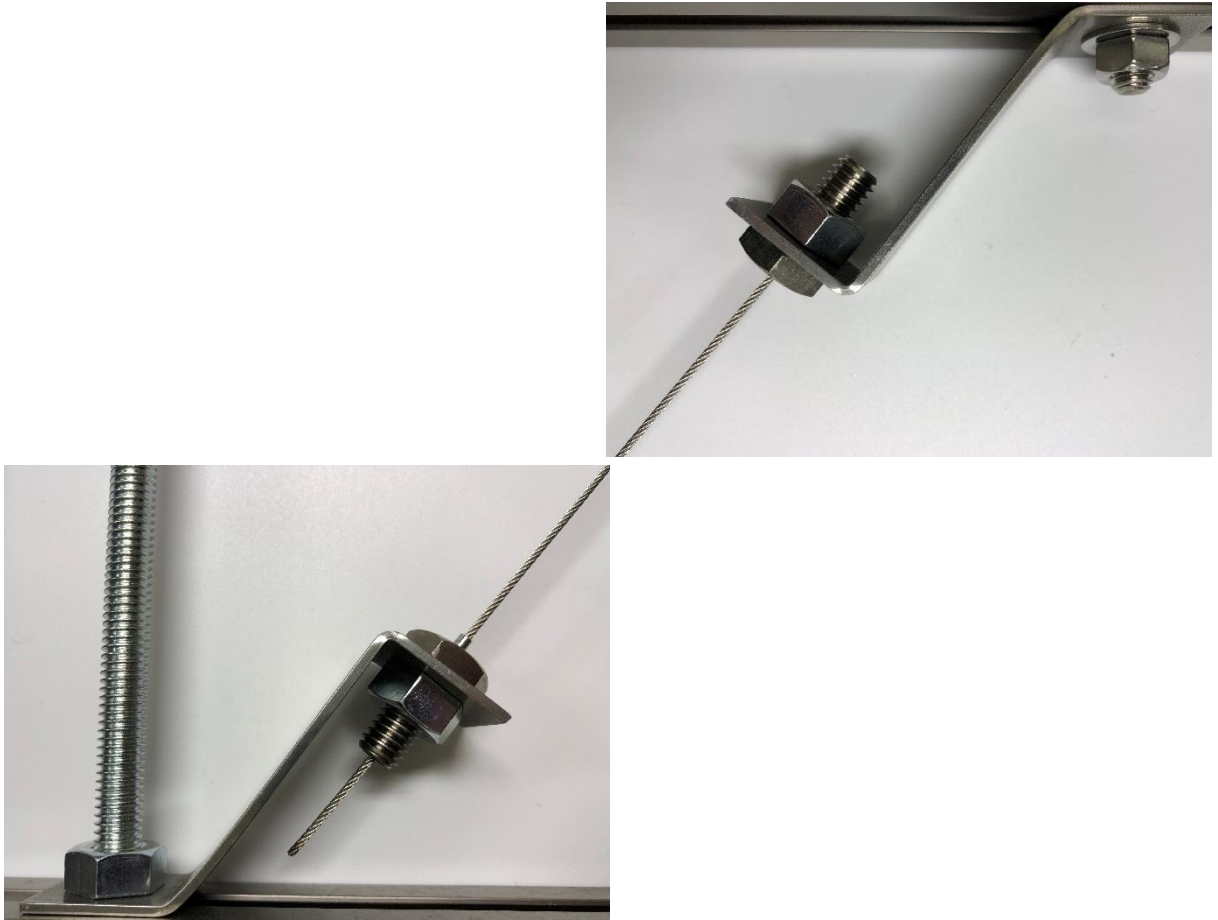

Ultima wire grips are widely used as anti-sway bars in equipment construction

Since its establishment, Ultima Wire Grips have been used in our products to meet the needs of the industry.

Ultima wire grips are characterized by their high gripping force while being gentle to the wire.

In fact, Ultima wire grips are used not only in the construction hardware industry, but also in the inspection equipment for wires used in industrial equipment and in the building equipment industry.

In particular, we have shipped more than 1 million units since 1990 to a certain electrical installation materials company in JAPAN as adjusting and fixing fixtures such as wire slide stoppers for equipment used to install lighting and air conditioning fixtures.*

* Products delivered have been discontinued due to changes in product specifications.

ULTIMA Anti-sway Wire System

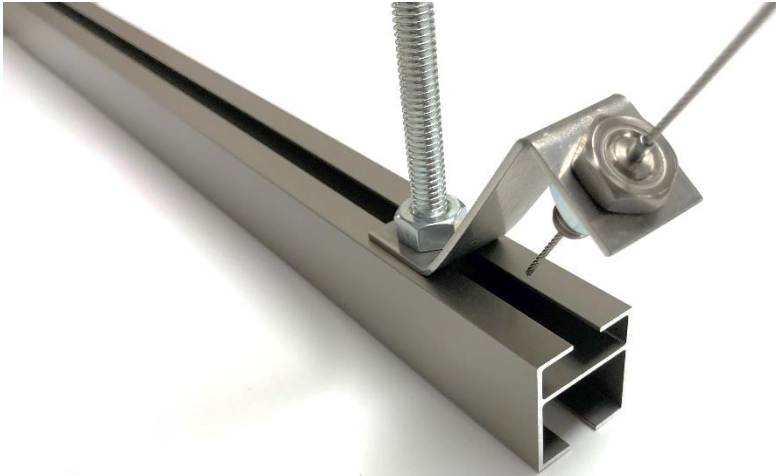

- More than 1 million units have been shipped as anti-sway wire for lighting, air conditioning, and other equipment.
- Because of the ease of attaching and detaching wires and adjusting wire positions, they are used in a variety of fields as industrial machinery parts and construction parts.
- They have earned a reputation for their unparalleled ease of use, especially for their strong fixation, high strength, and easy-to-integrate shape.

Wire	φ1.5、φ3.0
Allowable load value	Within 55 kg to 170 kg * Allowable load values vary depending on the wire diameter * Allowable load values are based on a safety factor of approximately 1/3 of the maximum static load value.
Main applications	Fixing of equipment, slide stopper, etc.
Main customers	Electrical equipment and materials companies, lighting equipment companies, and many others



Grip (wire anchor)

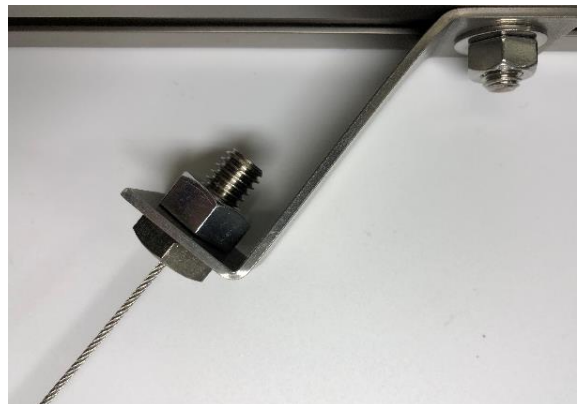

Wire (various edge)

Features

One-touch locking and adjusting function	<ul style="list-style-type: none">• Lock by simply inserting the wire. Unlock by operating the pin.• This simple operation reduces installation time and improves repair work efficiency.
High strength	<ul style="list-style-type: none">• The maximum static load of the grips is almost equal to the JIS standard for wires. It can be used within a sufficient safety factor. *1
Wire-friendly	<ul style="list-style-type: none">• The internal locking mechanism reduces damage to the wire and makes it safer, especially in the event of an impact.
Open design concept	<ul style="list-style-type: none">• Standard dimensions for easy incorporation into the design allow the use of commercially available nuts and anchors.
Compact design	<ul style="list-style-type: none">• The uniquely compact body expands the range of use.

*1 Japanese Industrial Standard

Attention

- Please use wire cutters for wire cutting to avoid fraying of strands.
- The grips have a strong locking force, so it may take more force to unlock the grips after a load is applied.
- The torque value of grips is lower than that of normal bolts because of the mechanism inside. Do not over-tighten the grips (the threads may be damaged).
- If the cut end of the wire is untwisted, it will be difficult to insert the wire into the grip. Cut the wire cleanly and twist it to insert it smoothly.
- Cut the excess wire that comes out of the grip, leaving 40 to 50 mm of excess wire. Please note that if the excess wire is forced and bent, it may affect the locking function.
- Do not use wires other than those specified by us. Also, for safety reasons, do not use damaged or bent wires.
- Do not allow the wire to come in direct contact with the edges as it may be cut or fall.
- The mounting position of the anti-sway bar should be firmly fixed near the supporting member.
- Do not use the product outdoors or in locations subject to high temperature, high humidity, shock or vibration.
- Do not apply paint or oil to the grips and wires.

What is the difference between Ultima grips and ordinary wire stopper fittings?

When wire grips are used to prevent equipment from swinging, common bearing-type grips are inadequate for the load.

In contrast, Ultima grips are strong enough to safely suspend heavy objects with smaller diameter wire.

Since 1990, we have shipped more than 1 million units of these grips to electrical installation material companies in Japan as adjustable fixtures to prevent wires from swinging when used in lighting and air-conditioning equipment.

Furthermore, as a feature of the grip, the length of the wire can be easily adjusted by operating the pin at the tip of the grip.

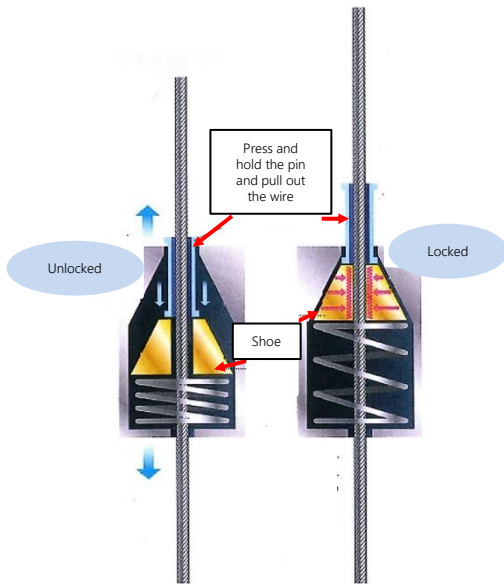

ULTIMA grip : Shoe type grip

Shoe type grips (surface fixation) distribute the load by clamping the wire between two surfaces, thereby reducing the load on the wire. The original strength of the wire is maintained.

The shoe-type grip is a proprietary technology of Ultima.

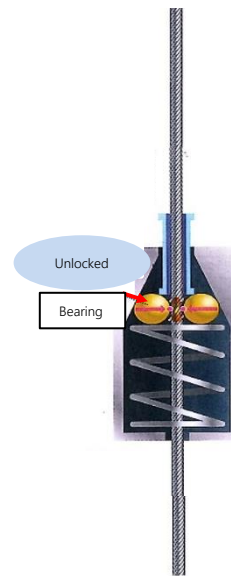

Other grip : Bearing type grip

Bearing type grips (point fixation) have less braking force because the force is concentrated at a single point, and the wire is easily damaged. The wire is easily damaged.

Safety	○	<ul style="list-style-type: none"> High strength and high safety ratio Utilized in industrial products 	△	<ul style="list-style-type: none"> Often utilized in display and interior design
Strength	○	<ul style="list-style-type: none"> Surface contact <u>Strong grip, especially resistant to vibration *1</u> 	×	<ul style="list-style-type: none"> Point contact Grip strength is low. Weak against shock and vibration *2
Release	×	<ul style="list-style-type: none"> Grip force is strong. Difficult to release by hand (finger) *3 	○	<ul style="list-style-type: none"> Grip force is low Easy to release by hand (finger)
Burden on wire	○	<ul style="list-style-type: none"> Surface fixation <u>Less burden due to distributed load</u> Less damage and indentation such as strand breakage and waviness 	×	<ul style="list-style-type: none"> Point fixation Load is concentrated, so there is a heavy burden. Damage and indentation such as strand breakage and waviness are inevitable. Wire maintenance is necessary
Production	○	<ul style="list-style-type: none"> <u>Original design, not an off-the-shelf product</u> <u>Other companies cannot easily manufacture (difficult to manufacture equivalent products)</u> 	×	<ul style="list-style-type: none"> Uses off-the-shelf bearings Easy to manufacture

*1 : 90% to 100% of JIS standard wire breaking load of 170kg based on SUS304p1.5mm (7*7) wire test values.

*2 : 50-70% of 170kg of JIS standard wire breaking load based on SUS304p1.5mm (7*7) wire test value.

*3 : Hybrid mechanism (pat.p) is also available to solve the disadvantage of difficulty in releasing the gripping force.

Basic grip operation

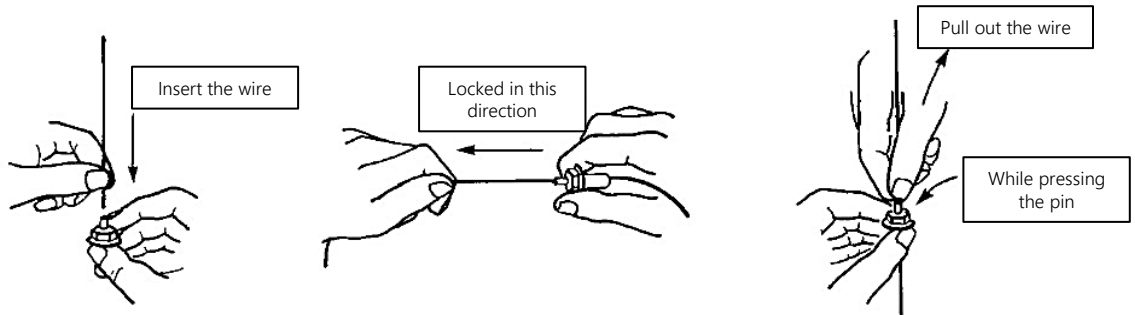

Grip strength



Wire	Maximum Static Load Value	Allowable Load Value
Φ1.5	1670N~1880N (170kg~192kg)	540N (55kg or less)
Φ3.0	5,390N (500kg)	1,670N (170kg or less)

- * The maximum static load value is the maximum value when a stainless steel wire (7 x 7) is used for the grip in a stationary state and pulled until the wire breaks (when it breaks).
- * The allowable load value is calculated with a safety factor of approximately 1/3 of the maximum static load value, but the safety factor should be considered depending on the conditions of use.
- * The maximum static load value varies depending on the type of wire used. Please contact us if you have any questions.

Comparison of allowable load value by wire diameter

Wire	ULTIMA grip : Shoe type grip	Other grip : Bearing type grip
Φ1.5	55kg or less	30kg or less
Φ3.0	170kg or less	100kg or less

Product Specifications (wire)

	Hex terminal wire on one side	Ball terminal wire on one side
		
Wire Length	L=1,000, L=2,000	
Material	Wire : SUS 304 (7×7)	
Wire Set	Φ3.0 wire set A	Φ1.5 wire set A
Note	-	-

* Do not use any wire other than the special wire provided by the Company.

* Standard wire grip dimensions are L=1,000 and 2,000 mm. Please consult us for other dimensions.

Product Drawing (wire)

Φ3.0



Hex terminal wire on one side : φ3.0 wire set A

Φ1.5



Ball terminal wire on one side : φ1.5 wire set A

Wire with M6 eyebolt	Wire with W3/8 eyebolt	Fused wire on both sides
----------------------	------------------------	--------------------------



Wire Length	L=1,000, L=2,000	
Material	Wire : SUS 304 (7×7) M6 eyebolt·W3/8 eyebolt : Steel, nickel plated	SUS 304 (7×7)
Wire Set	Φ3.0 wire set C Φ1.5 wire set C	Φ3.0 wire set B Φ1.5 wire set B
Note	With M6 eyebolt, nut	With W3/8 eyebolt, nut

* Do not use any wire other than the special wire provided by the Company.

* Standard wire grip dimensions are L=1,000 and 2,000 mm. Please consult us for other dimensions.

Product Drawing (wire)

Φ3.0



Wire with M6 eyebolt : φ3.0 wire set C

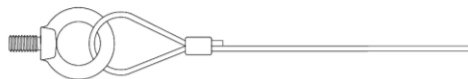

Wire with W3/8 eyebolt : φ3.0 wire set D

Φ1.5



Wire with M6 eyebolt : φ1.5 wire set C



Wire with W3/8 eyebolt : φ1.5 wire set D



Product Specifications (Grip and end fitting)

Grip + End fitting Plate : ULP-3002



Product	Left: ULG-3012 (grip section) Right: ULG-3012 A (end section)	Left: ULG-1509 (grip section) Right: ULG-1509 A (end section)	Plate ULP-3002
Wire	Φ3.0	Φ1.5	-
Screw specification	M12	W3/8	-
Material	brass, steel		SUS
Finishing	Unichrome plating		-
Note	with nut		Hole diameter φ12 (common to φ3.0 and φ1.5)

- * Ultima grips are designed with a limited wire diameter for safety reasons, even though the external shape is the same.
- * For improvement, the shape and specifications are subject to change without notice.

Product Drawing

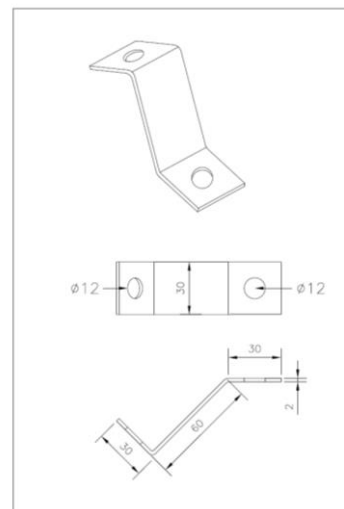
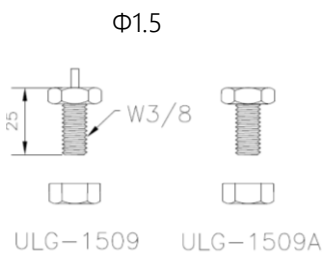
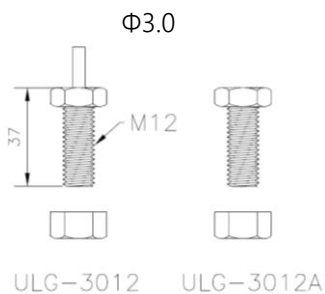

Wire set





To combine Ultima Anti-sway wire system, simply select the grip (wire clamp) and the wire end part that matches the installation location.

※ ULG-3012 and ULG-3012 A include nuts, and ULG-1509 and ULG-1509 A include nuts.







※ Wire length can be selected from L=1,000 or L=2,000

※ When installing, please consider the strength of suspension fittings, support materials, etc.

ULTIMA Anti-Sway Wire System Wire set $\phi 3.0$

Products		$\phi 3.0$ wire set A	$\phi 3.0$ wire set B	$\phi 3.0$ wire set C	$\phi 3.0$ wire set D
Grip + end fitting	 ULG-3012 (grip)	1 set	2 set	1 set	1 set
	 ULG-3012 A (end fitting)	1 set	-	-	-
	 ULP-3002 (plate)	2 set	2 set	1 set	1 set
Wire	 $\phi 3.0$ hex terminal wire on one side	1 set	-	-	-
	 $\phi 3.0$ fused wire on both side	-	1 set	-	-
	 $\phi 3.0$ wire with M6 eyebolt	-	-	1 set	-
	 $\phi 3.0$ wire with W3/8 eyebolt	-	-	-	1 set

ULTIMA Anti-Sway Wire System Wire set $\phi 1.5$

Product		$\phi 1.5$ wire set A	$\phi 1.5$ wire set B	$\phi 1.5$ wire set C	$\phi 1.5$ wire set D
Grip + end fitting	 ULG-1509 (grip)	1 set	2 set	1 set	1 set
	 ULG-1509 A (end fitting)	1 set	-	-	-
	 ULP-3002 (plate)	2 set	2 set	1 set	1 set
Wire	 $\phi 1.5$ ball terminal wire on one side	1 set	-	-	-
	 $\phi 1.5$ fused wire on both sides	-	1 set	-	-
	 $\phi 1.5$ wire with M6 eyebolt	-	-	1 set	-
	 $\phi 1.5$ wire with W3/8 eyebolt	-	-	-	1 set

Wire set Line up_φ3.0

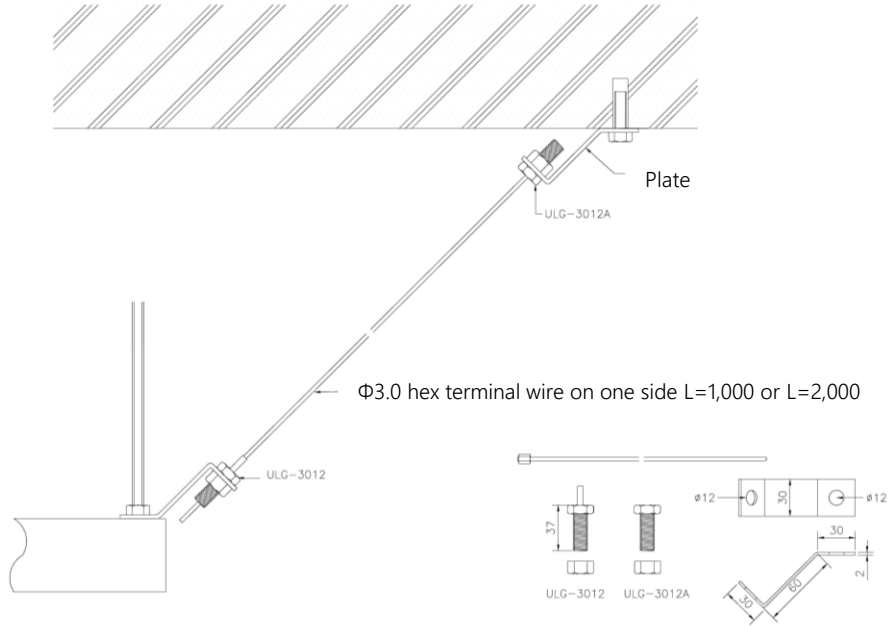

Φ3.0 wire set A		
ULG-3012 (with plate and nut) × 1set	ULG-3012 A (with plate and nut) × 1set	φ3.0 hex terminal wire on one side L=1,000 or L=2,000 ×1set

* Allowable load value: ULG-3012A is 170kg. When installing, please consider the strength of suspension fittings, support materials, etc.

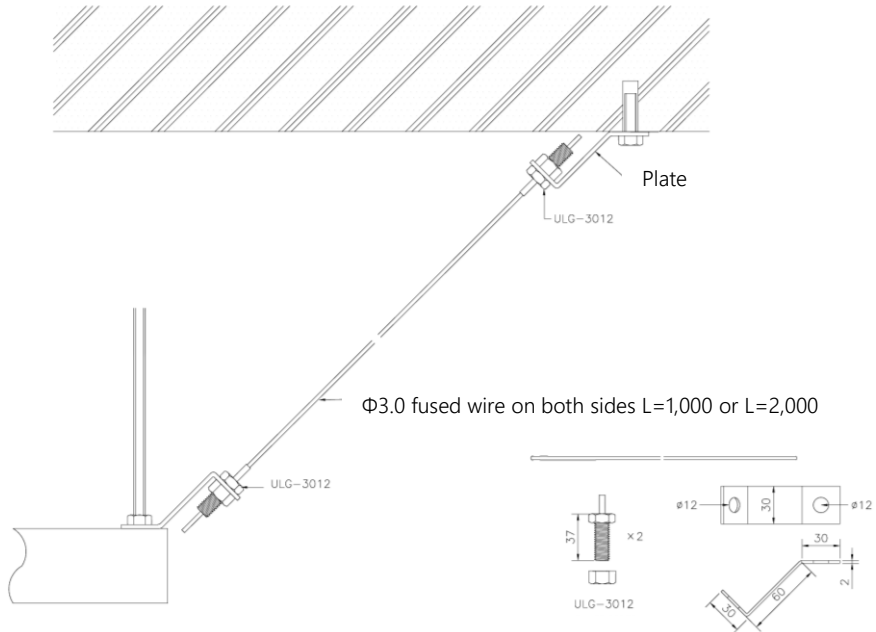

Φ3.0 wire set B	
ULG-3012 (with plate and nut) × 2set	Φ3.0 fused wire on both sides L=1,000 or L=2,000 × 1set

* Allowable load value: ULG-3012A is 170kg. When installing, please consider the strength of suspension fittings, support materials, etc.

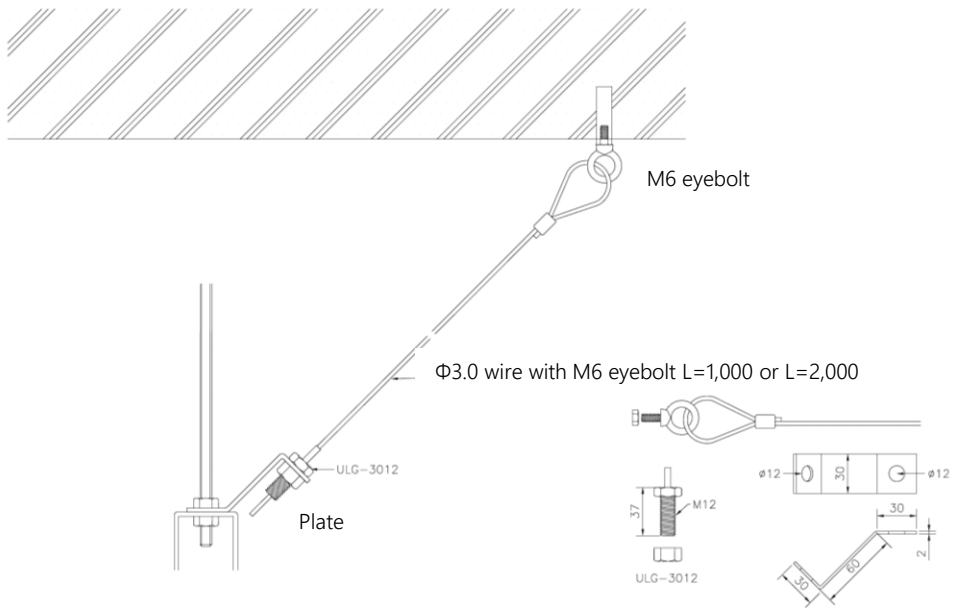

Φ3.0 wire set C

ULG-3012 (with plate and nut) × 1set

Φ3.0 wire with M6 eyebolt L=1,000 or L=2,000 ×1set

* Allowable load value: 170 kg for wire caulking with M6 eyebolt.

When installing, please consider the strength of suspension fittings, support materials, etc.

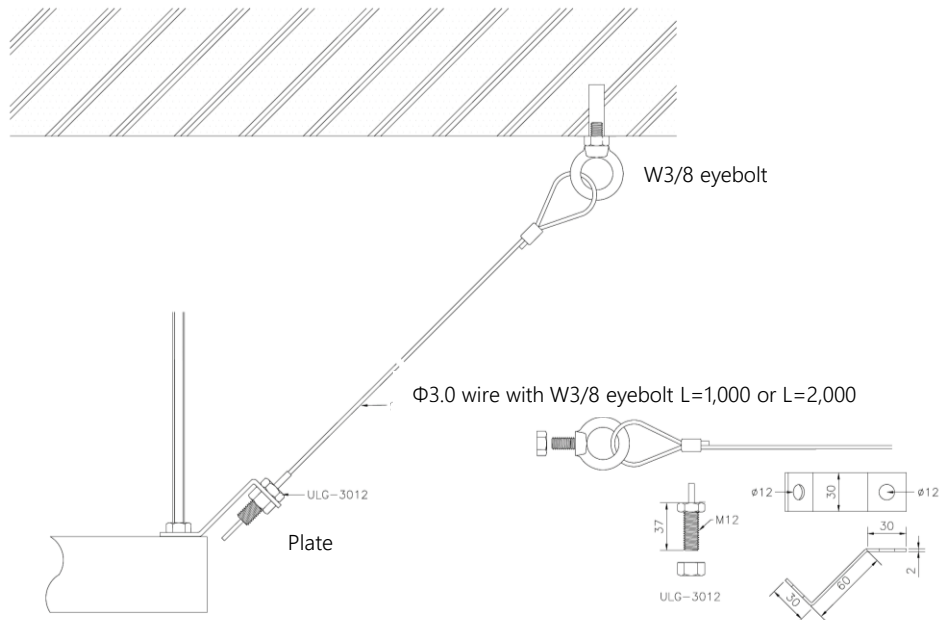

Φ3.0 wire set D

ULG-3012 (with plate and nut) × 1set

Φ3.0 wire with W3/8 eyebolt L=1,000 or L=2,000 ×1set

* Allowable load value: 170 kg for wire caulking with W3/8 eyebolt.

When installing, please consider the strength of suspension fittings, support materials, etc.

Wire set Line up_φ1.5

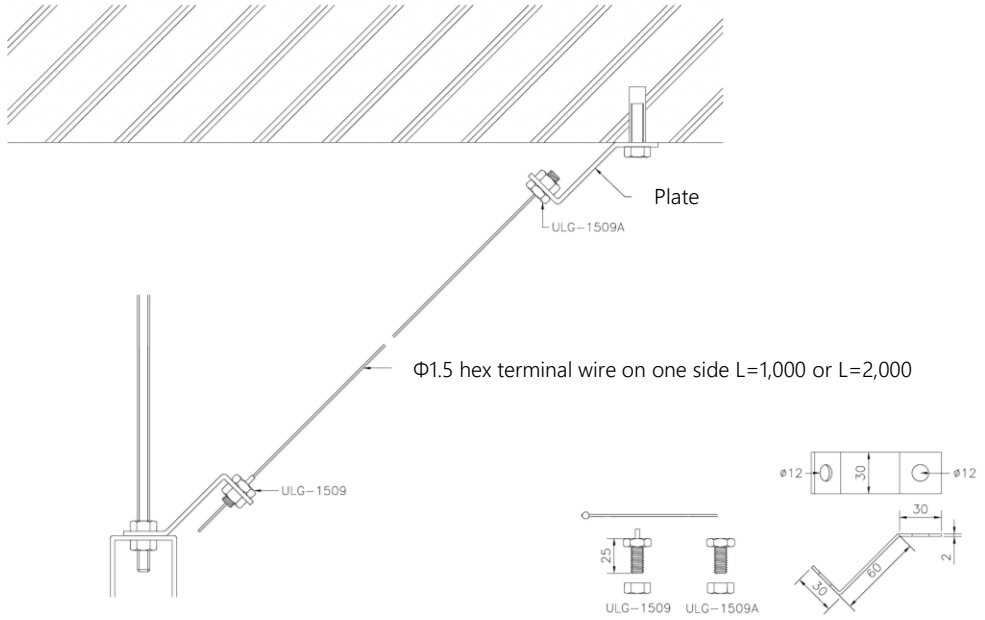

Φ1.5 wire set A		
ULG-1509 (with plate and nut) × 1set	ULG-1509 A (with plate and nut) × 1set	Φ1.5 hex terminal wire on one side L=1,000 or L=2,000 × 1set

* Allowable load value: ULG-1509A is 60kg. When installing, please consider the strength of suspension fittings, support materials, etc.

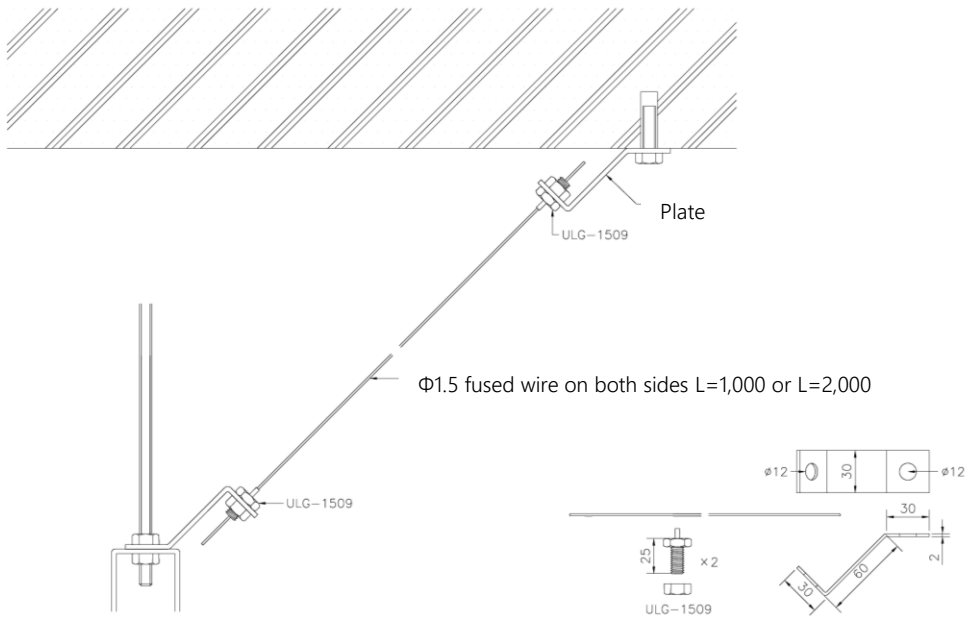

Φ1.5 wire set B	
ULG-1509 (with plate and nut) × 2set	Φ1.5 fused wire on both sides L=1,000 or L=2,000 × 1set

* Allowable load value: ULG-1509A is 60kg. When installing, please consider the strength of suspension fittings, support materials, etc.

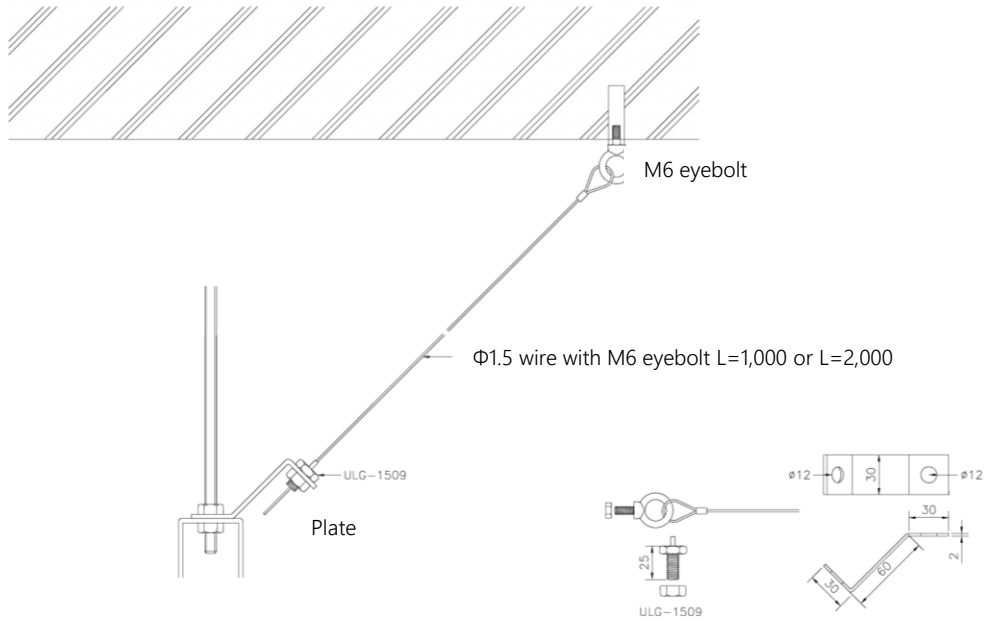

Φ1.5 wire set C	
ULG-1509 (with plate and nut) × 1set	Φ1.5 wire with M6 eyebolt L=1,000 or L=2,000 × 1set

* Allowable load value: 45 kg for wire caulking with M6 eyebolt.

When installing, please consider the strength of suspension fittings, support materials, etc.

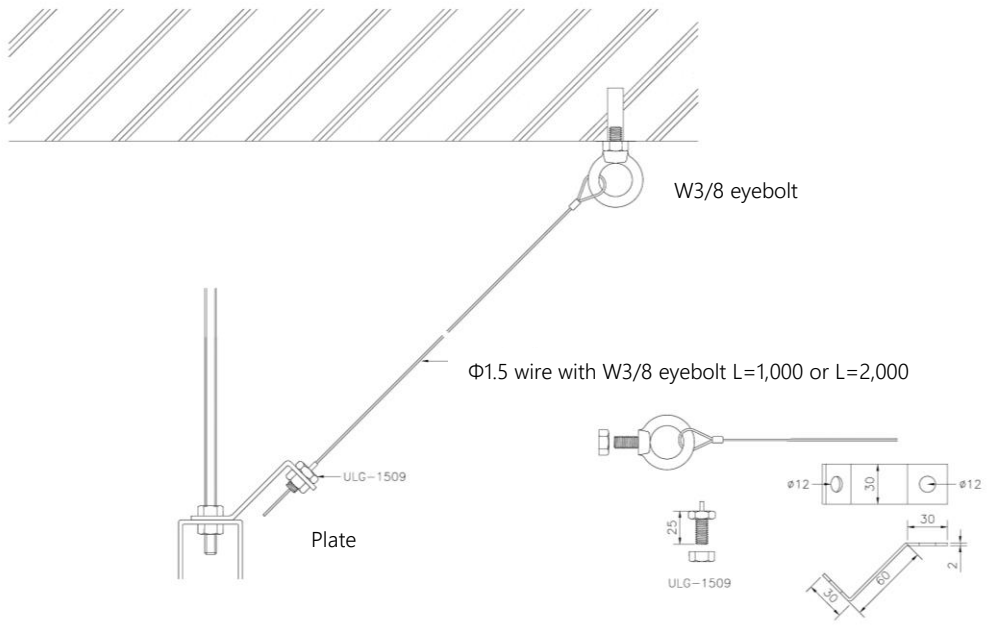

Φ1.5 wire set D	
ULG-1509 (with plate and nut) × 1set	Φ1.5 wire with W3/8 eyebolt L=1,000 or L=2,000 × 1set

* Allowable load value: 45 kg for wire caulking with W3/8 eyebolt.

When installing, please consider the strength of suspension fittings, support materials, etc.

Instruction (wire set A)

* The installation procedure is the same for wire diameters of 3.0 and 1.5 mm.

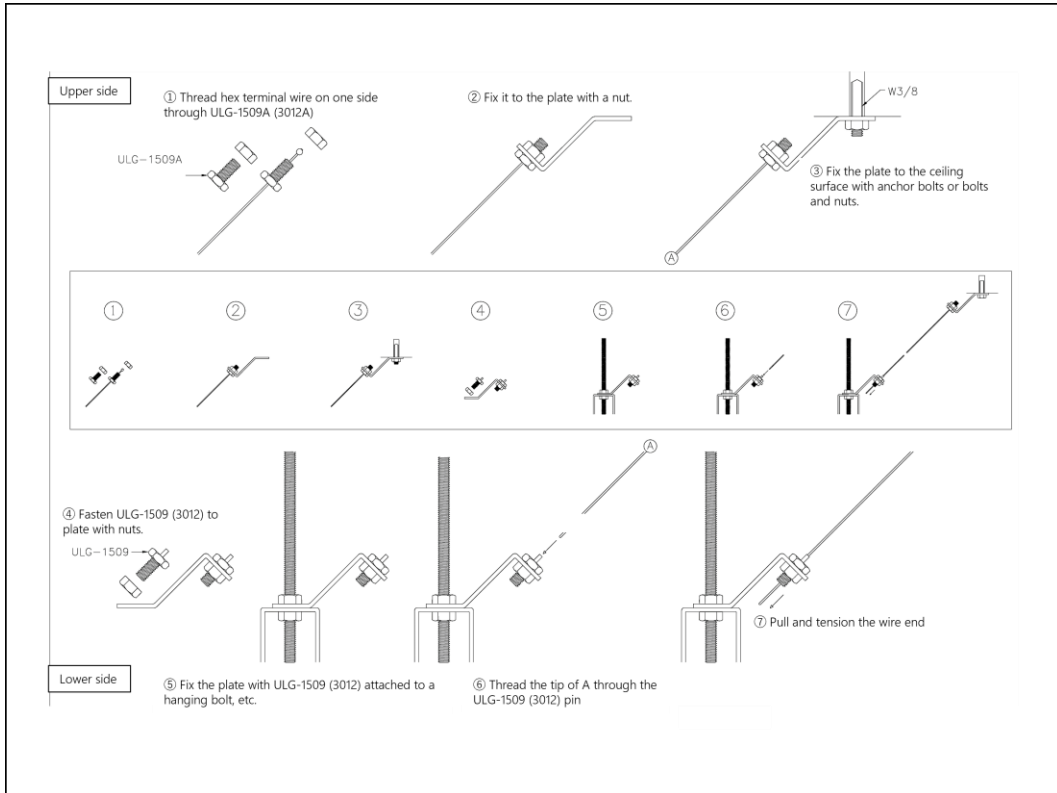

Instruction (wire set B)

* The installation procedure is the same for wire diameters of 3.0 and 1.5 mm.

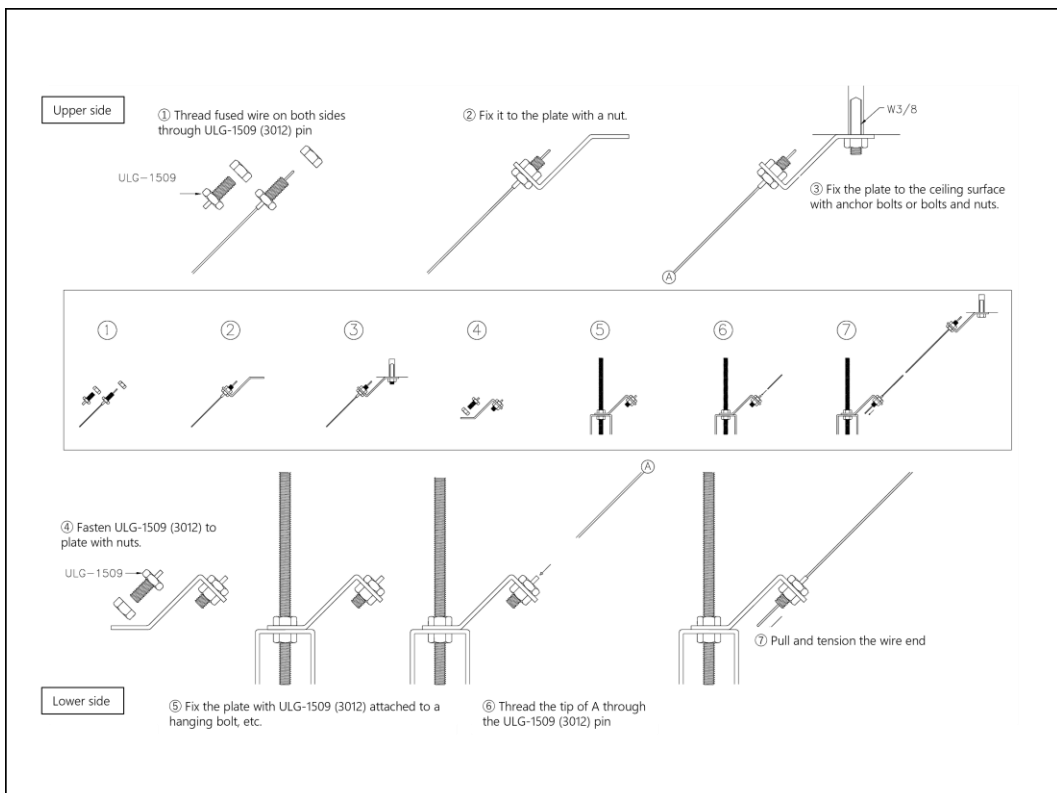

Instruction (wire set C, D)

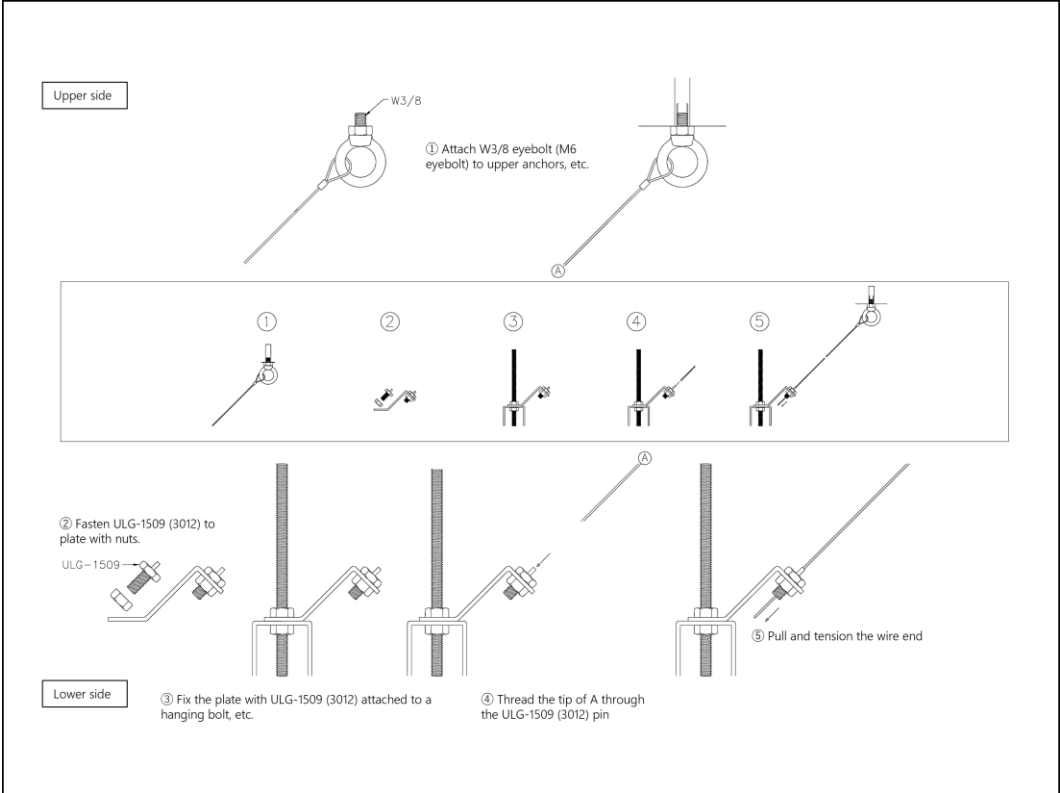

ULTIMA Turnbuckle_ ϕ 3.0



- The turnbuckle and connecting wire grip are integrated into a single unit, giving a slim, clean look to the space.
- The one-touch locking function allows the wire grip to be attached and detached with a pin operation, greatly reducing installation work.

Wire	ϕ 3.0
Allowable load value	Within 65 kg to 100 kg * Allowable load values are based on a safety factor of approximately 1/3 of the maximum static load value.
Main applications	Stop swinging signs at public facilities, etc.
Main customers	Train stations, public facilities, commercial facilities, pergolas, and many others



Vibration stopper in station

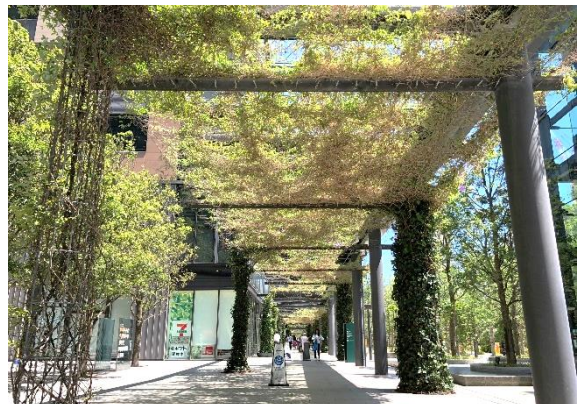

Facedes

Case study



Station building



Facade



Botanical garden



Parking



Lighting

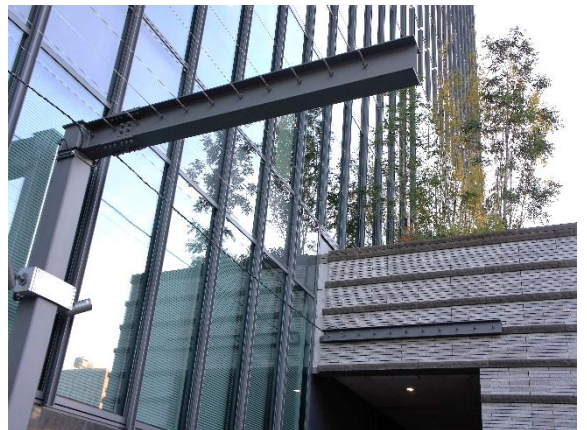

Facade

Why would a designer choose Ultima turnbuckle?

Around 2002, when designing a new station building for a certain railroad company, the architect said to me something like this.

"I was so disappointed because the turnbuckles on the signage were so dirty, even though the platform and walls were landscaped beautifully. Can you make a more sophisticated turnbuckle with your company?"

Certainly there is nothing ingenious about conventional turnbuckles.



Conventional turnbuckle

Conventional turnbuckle

- It is difficult to pull wire grips...
- It is difficult to turn the turnbuckle in a narrow scaffold.
- The design is not ingenious and does not look good.

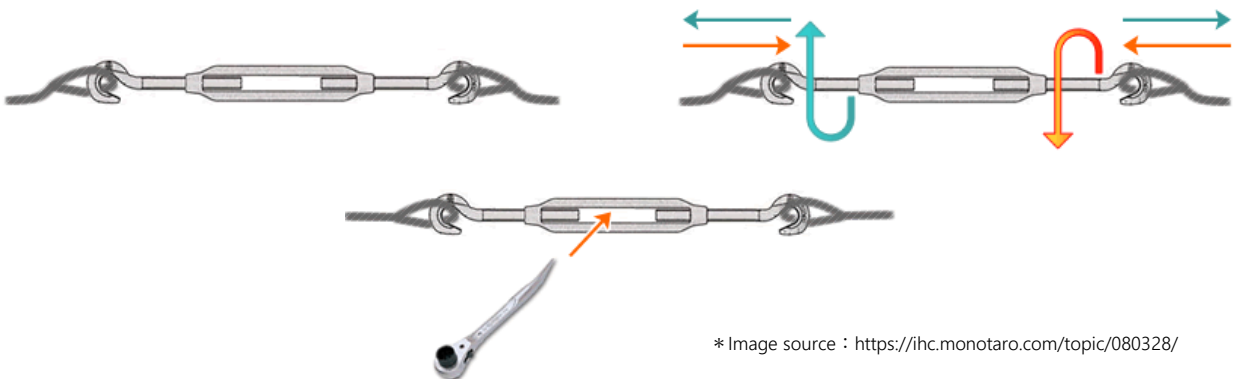

* Image source : <https://ihc.monotaro.com/topic/080328/>

The conventional turnback installation procedure is,

1. Hook the wire to the end hook.
2. By turning the middle section, the hooks at both ends are extended and retracted to create tension.
3. If you can no longer turn it by hand, insert a tool into the middle part and turn it to apply more tension to the wire.

Ultima turnbuckle are beautifully designed and easy to install, while maintaining the original specifications of the turnbuckle.



ULTIMA turnbuckle

ULTIMA turnbuckle

- Slim body with integrated turnbuckle and connecting wire grip
- One-touch locking function allows the wire to be attached or detached by a pin operation, greatly reducing the installation work.
- High gripping force enables installation over a long span (approx. 10 m)



ULTIMA turnback installation procedure is,

1. Insert the wire into the grip
2. Insert the wire from the grip into the long hole of the main unit and screw the grip into the main unit case.
3. Pull the wire coming out of the long hole by hand, hold the tip of the grip with a wrench, and turn the main body case to apply tension.

Product Specifications (turnbuckle)

	UTB-30BN	UTB-30CN	UTB-30DN
			
End Shape	Hook	Eye	Straight
Pipe hole shape	Long hole		
Wire	Stainless : φ3		
Material	Stainless		
Allowable Load Value	SUS : 640N (65kg or less)	SUS : 980N (100kg or less)	
Note	Adjustable wire length		

* Precautions for handling

Safety load is the strength of the turnbuckle side. Please consider the strength of suspension fittings, support materials, etc. when installing.

Shape and specifications are subject to change without notice for improvement.

UTB-30BN (end shape : hook)

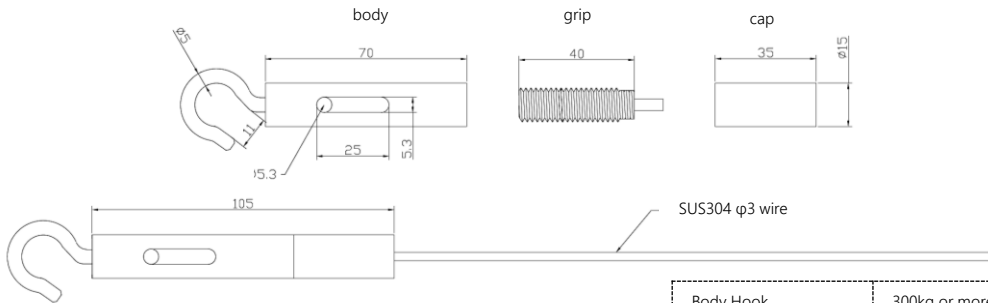

Body Hook	300kg or more
Wire hook	300kg or more
Wire Grip	500kg (practical 200~300kg)
Caulking part	400kg or more
Wire breaking strength	660kg

UTB-30CN (end shape : eye)

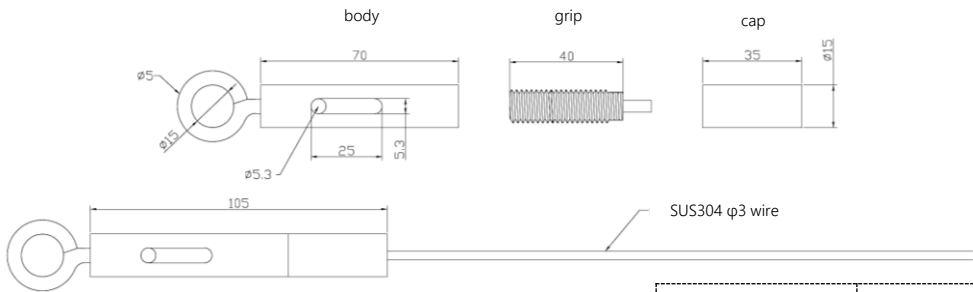

Body Hook	300kg or more
Wire hook	300kg or more
Wire Grip	500kg (practical 200~300kg)
Caulking part	400kg or more
Wire breaking strength	660kg

UTB-30DN (end shape : straight)

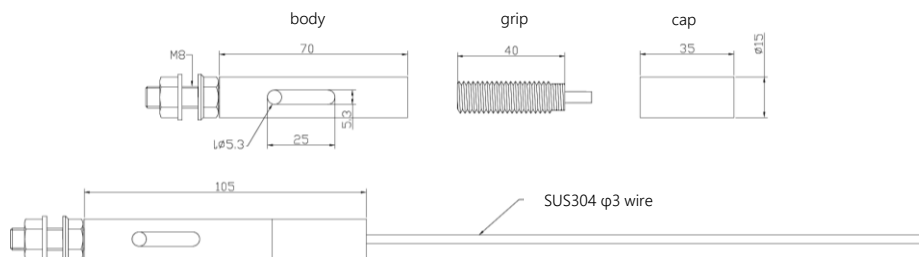

Wire hook	300kg or more
Wire Grip	500kg (practical 300~400kg)
Caulking part	300kg or more
Wire breaking strength	660kg

Product Specifications (wire)

Hook	Loop
------	------



Wire	Φ3	
How to use	Mating side support material is eye-shaped metal fittings: Hook (SUS)	Loop through support material such as beam, column, etc.: Loop diameter φ45
Material	SUS 304 (7×7)	
Wire length	build-to-order manufacturing	

* All turnbuckle sides are fused together. Please select the shape of the mating side of the turnbuckle.

* Do not use any wire other than the special wire provided by us.

* Standard dimensions of wire grip are L=2000、3000mm. Please consult us for other dimensions.

Fusion



Wire	Φ3	
How to use	If the other side is also a turnbuckle, both ends are fused.	
Material	SUS 304 (7×7)	
Wire length	build-to-order manufacturing	

Wire grip shape : Hook



Instruction (UTB-30BN)

① Remove the cap and wire grip from the body



② Thread the cap through the wire first, then insert the wire into the grip (let the wire out about 10-15 cm)



③ Pull the wire out of the grip and out of the main body



④ Turn the main body and screw the grip 2-3 threads



⑤ Pull the wire out of the long hole by hand



⑥ After pulling the wire by hand, hold it with a wrench (10 mm) at the end of the grip and turn the main body to stretch it (using the hole in the main body with a screwdriver, etc.)

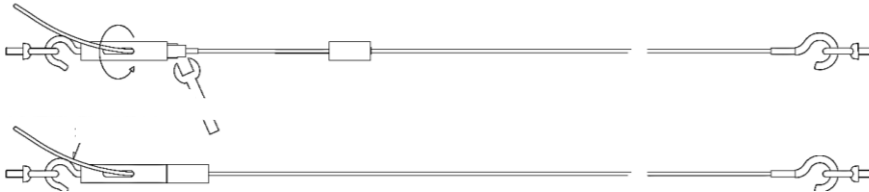

⑦ After tensioning adequately, tighten the cap to complete the process (If cutting excess wire, leave about 50 to 100 mm)

- It is not suitable for hanging objects.
- The safety load is the strength of the turnbuckle side. When installing, please consider the strength of the suspension fittings and support materials.
- Adjustment of the level should be done with no load applied.
- Do not use the product in a place where there is vibration.
- Do not apply paint or oil to the body or wires.
- If the cut end of the wire is loose, it will be difficult to insert it into the grip section.
- Do not use wires other than those specifically designed for Ultima Turnbuckle.
- Standard wire dimensions are L=2,000mm and L=3,000mm. Please consult us for other dimensions.
- Select the end shape of the wire according to the mating end.
- For the support part, choose from fusion welding, terminal, loop, or hook. For example, if the support is also a turnbuckle, both ends should be welded, if the support is a terminal fitting, it should be a terminal, and if the support is a pillar or beam, it should be a loop.

Re-tensioning (UTB-30BN、30CN)

① Remove the cap, hold the grip with a wrench, and turn the body to loosen it.

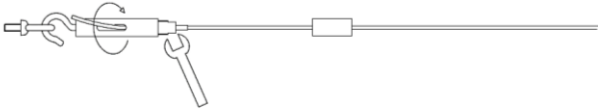

② Loosen until the grip screw part comes out 20 to 25 mm.



③ Pull the excess wire with a tool to loosen the wire (pull hard to unlock)



④ Hold the grip with a wrench and turn it in the opposite direction from when it was loosened to tension the wire

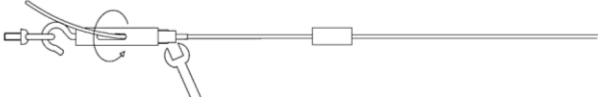

⑤ Put the cap back on



Instruction (UTB-30DN)

① Remove the cap and wire grip from the body

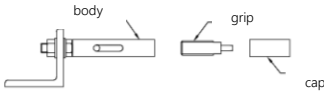

Attention :

- Be careful not to pull too much when applying tension
- This will put a strain on the angle and may result in bending or other problems.

② Thread the cap through the wire first, then insert the wire into the grip (let the wire out about 10-15 cm)



③ Pull the wire out of the grip and out of the main body



④ Turn the main body and screw the grip 2-3 threads



⑤ Pull the wire out of the long hole by hand



⑥ After pulling the wire by hand, hold it with a wrench (10 mm) at the end of the grip and turn the main body to stretch it (using the hole in the main body with a screwdriver, etc.)



⑦ After tensioning adequately, tighten the cap to complete the process (If cutting excess wire, leave about 50 to 100 mm)

- Be careful not to pull too much when applying tension. Not suitable for hanging objects.

FAQ

Q1. How many wire diameters are available?

Specified wire diameters are limited to $\phi 1.5$ and $\phi 3.0$, and turnbuckles are limited to $\phi 3.0$.

For safety reasons, please do not use other than the specified wire diameters.

Q2. What is the allowable load for grips?

It ranges from within 55 kg to 170 kg.

The allowable load value is set at a safety factor of approximately 1/3 of the maximum static load value, and the allowable load value varies depending on the wire diameter.

Wire	Maximum Static Load Value	Allowable Load Value
$\phi 1.5$	1670N~1880N (170kg~192kg)	540N (55kg or less)
$\phi 3.0$	5,390N (500kg)	1,670N (170kg or less)

Q3. What is the allowable load for turnbuckles?

The UTB-30BN with hook end shape is within 65 kg with SUS wire.

UTB-30CN with eye end and UTB-30DN with straight end are within 100kg with SUS wire.

The allowable load value is set at a safety factor of approximately 1/3 of the maximum static load value.

Q4. What kind of processing is available for turnbuckle-specific wire?

The turnbuckle side is fused processing. On the other side, please select from 4 types of processing: with hook fittings, with terminal fittings, with loop processing, and with fusion welding.

Q5. Can you provide custom wire lengths?

We can provide the standard lengths of L=1,000 and L=2,000, and the standard lengths of L=2,000 and L=3,000 for the turnbuckles.

For longer spans, we will manufacture by special order. Please contact us for delivery date and price.

ULG ULTIMA Co.,Ltd.
Ultima Line Grip